

# MATHEMATICS

YEAR 5

TEST 5B

LEVELS  
**3-5**

CALCULATOR ALLOWED

Total marks



Name

Class

School

Date

## Instructions

You **may** use a calculator to answer any questions in this test.

---

Work as quickly and as carefully as you can.

You have **45 minutes** for this test.

If you cannot do one of the questions, **go on to the next one**.

You can come back to it later, if you have time.

If you finish before the end, **go back and check your work**.

---

Follow the instructions for each question carefully.



This shows where you need to put the answer.



If you need to do working out, you can use any space on a page.

---

Some questions have an answer box like this:

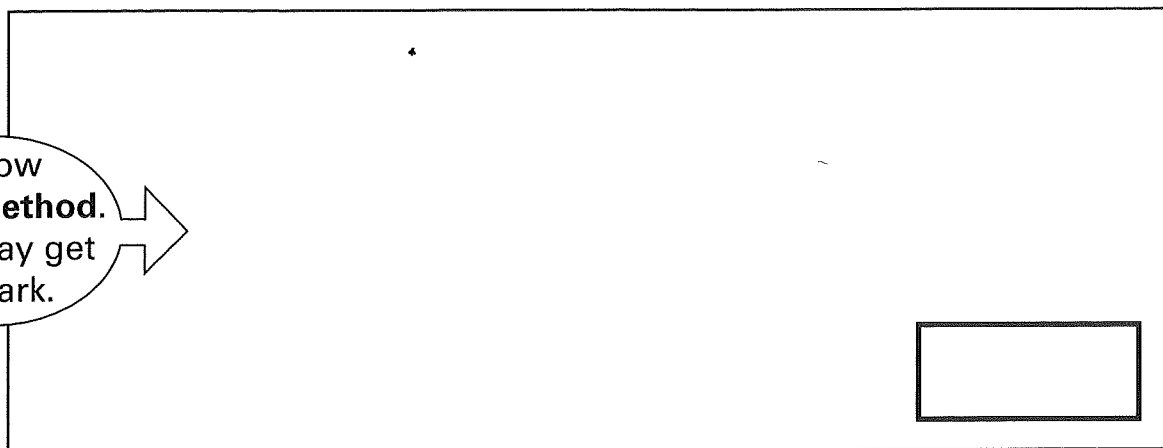

Show  
your **method**.  
You may get  
a mark.



For these questions you may get a mark for showing your method.

---

**1**

Write in the missing numbers.

 $150 \times \square = 600$

1a  
1 mark

$\square - 100 = 150$

1b  
1 mark**2**

Here are four digit cards.

3

4

5

6

Use three of them to make this correct.

 $\square\square - \square = 47$

2  
1 mark

3

Match each picture of a shape to its name.

One has been done for you.

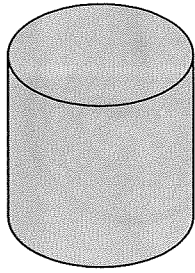

cube

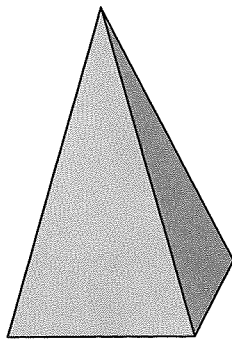

cuboid



cylinder



pyramid

triangular prism

3

1 mark

4

Reshma has some notes and some coins.

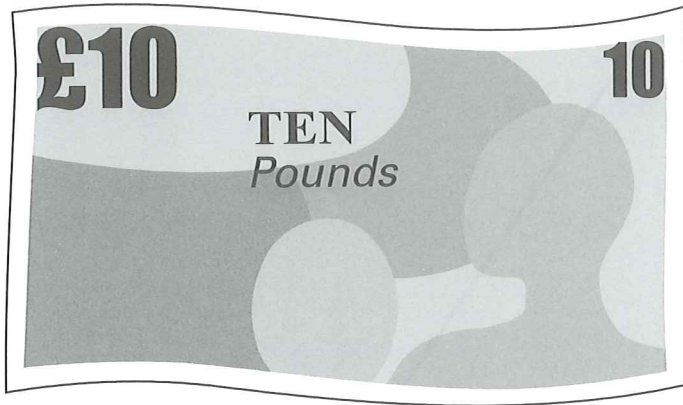

How much money does Reshma have?



£

4  
1 mark

5

The children in Farm School Orchestra each play one instrument.



The table shows how many children play each instrument.

	instrument	number of children
woodwind	recorder	23
	clarinet	4
	flute	5
percussion	drum	1
	piano	2
string	violin	7

How many **more** children play a recorder than play a violin?



5a

1 mark

How many of the children do **not** play a percussion instrument?



5b

1 mark

6

Here are some numbers.

6

2

32

5

Write each number in a box to make this number story correct.



There are  sweets in a bag.

friends share them equally.

Each friend gets  sweets.

sweets are left over.

6

1 mark

7

Mr Barker takes his class to a museum.

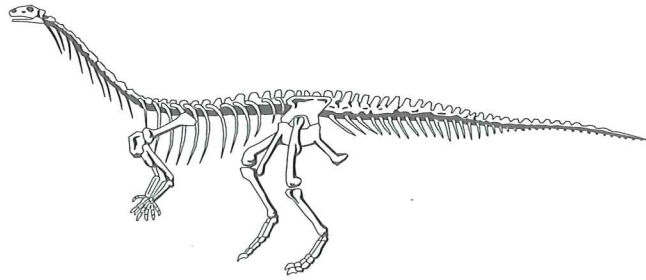

They enter the dinosaur display at 12:45pm.

They leave at 1:30pm.

How long do they spend at the dinosaur display?  
Circle the correct answer.



$\frac{1}{4}$  hour

$\frac{1}{2}$  hour

$\frac{3}{4}$  hour

1 hour

more than  
1 hour

7  
1 mark



8

Here is part of a number grid.

2	4	6	8	10
12	14	16	18	20
22	24	26	28	30
32	34	36	38	40

Here is another part of the **same** grid.

Write in the missing numbers.

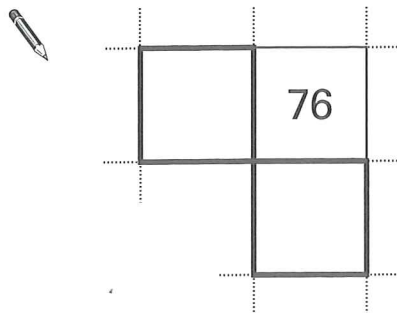

8

1 mark

9

Here is a jug with some water in it.

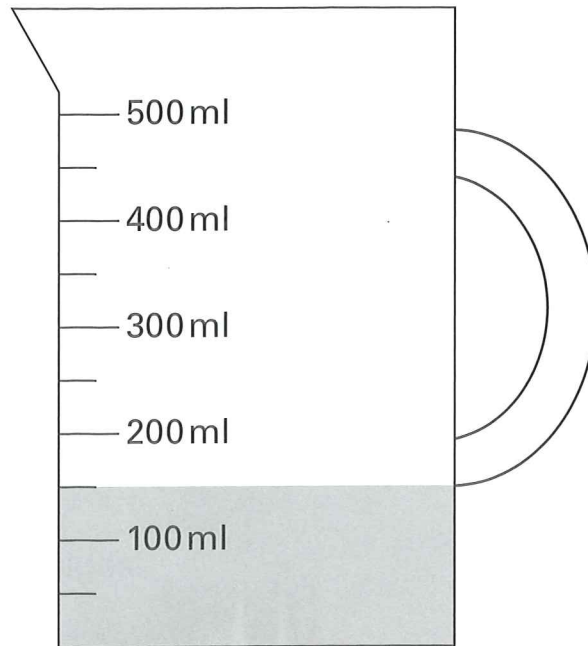

How many **more** millilitres of water must be added so that there are **500 ml** in the jug?



9

1 mark

10

Emma drew this shape.

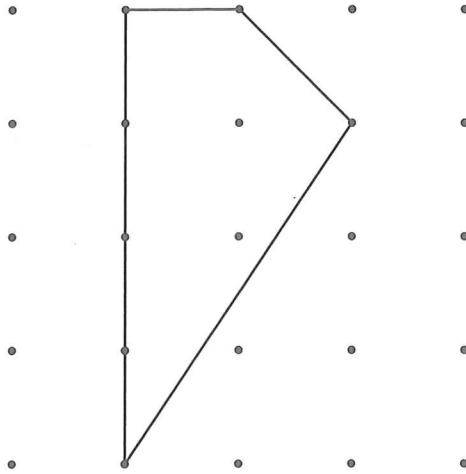

Draw how Emma's shape will look after a **half-turn**.

One line has been drawn for you.

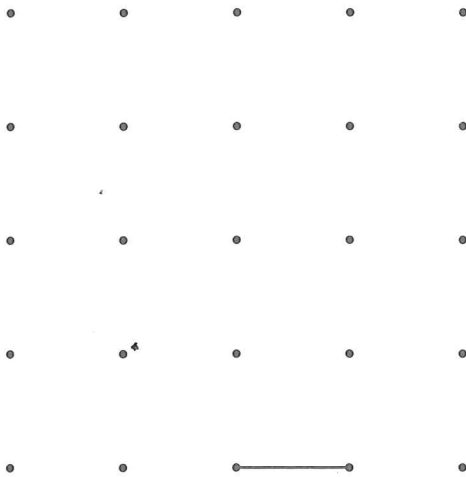

**11**

Here is part of a number line.

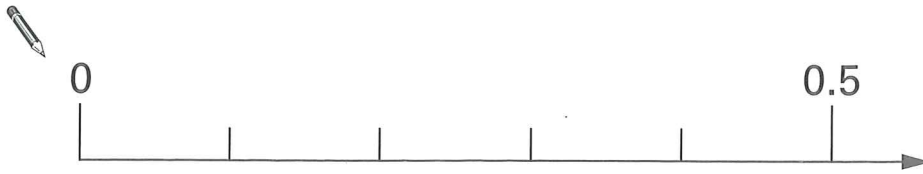
Draw an arrow ( $\downarrow$ ) to show the position of **0.32**

11

1 mark

**12**

Here are three signs.

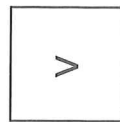
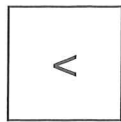
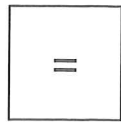

Write in the signs to make these correct.

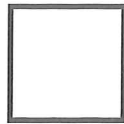

100

 $10 \times 10$ 

100

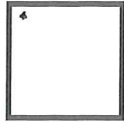
 $15 \times 5$ 

100

 $20 \times 6$ 

12

1 mark

13

Here is a shaded shape on a square grid.

Draw the reflection of the shape in the mirror line.

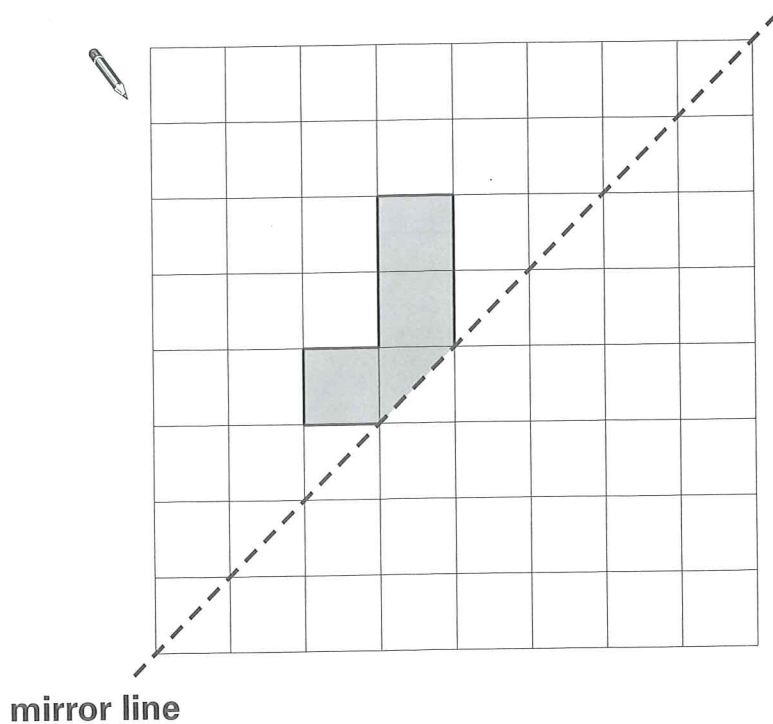

13

1 mark

14

Here is a sorting diagram.

Write a correct number in each of the two boxes.

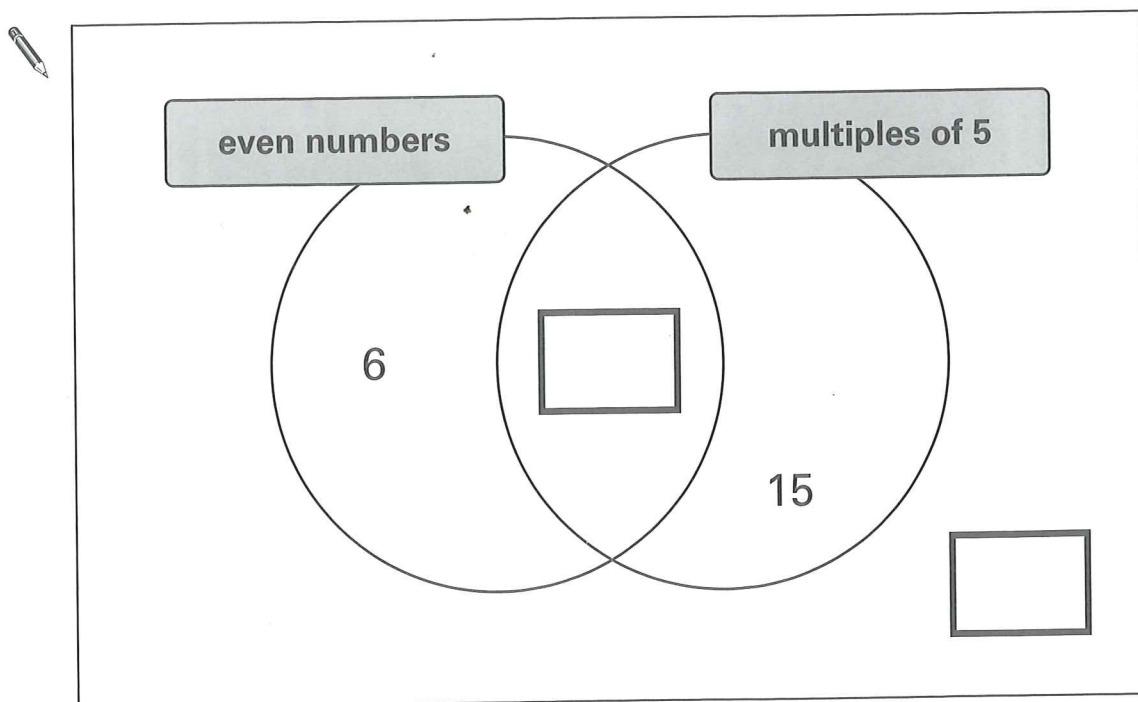

14

1 mark

15

Luke buys 750 grams of apples.

Each apple weighs between 140 grams and 160 grams.

Circle the number of apples that Luke buys.



4

5

6

7

8

15

1 mark

16

Here is a shape made from matching triangles.

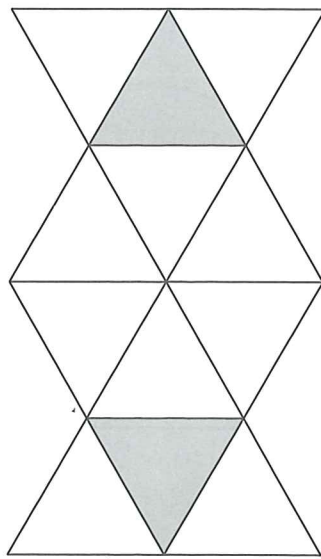

Circle the fraction of the shape that is shaded.



$\frac{1}{2}$

$\frac{1}{3}$

$\frac{1}{4}$

$\frac{1}{5}$

$\frac{1}{6}$

16

1 mark

17

These are the prices of fruit in a shop.

Oranges  
5 for 90p



Cherries  
80p for 100 grams

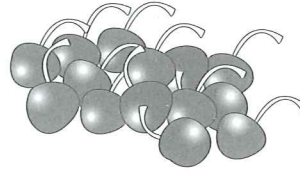

Emma buys 15 oranges.

How much does she pay?



17a  
1 mark

Reshma buys some cherries.

They cost £1.20

How many grams of cherries does she buy?



Show  
your **method**.  
You may get  
a mark.

 g

17b  
17c  
2 marks

Luke sorts a set of numbers to find those that are odd.



He says,

*'I only need to look at the last digit to know  
if a number is odd.'*

Is Luke correct?  
Circle **Yes** or **No**.



Yes / No

Explain how you know.

A large, empty, cloud-shaped box with a scalloped border, intended for the student to write their explanation. A small pencil icon is positioned at the top left corner of the box.



19

Write in four digits to make this correct.



--	--

 × 

--	--

 = 

1	1	0	0
---	---	---	---

19  
1 mark

20

Draw two more lines on this grid to complete the rectangle.

Use a ruler.

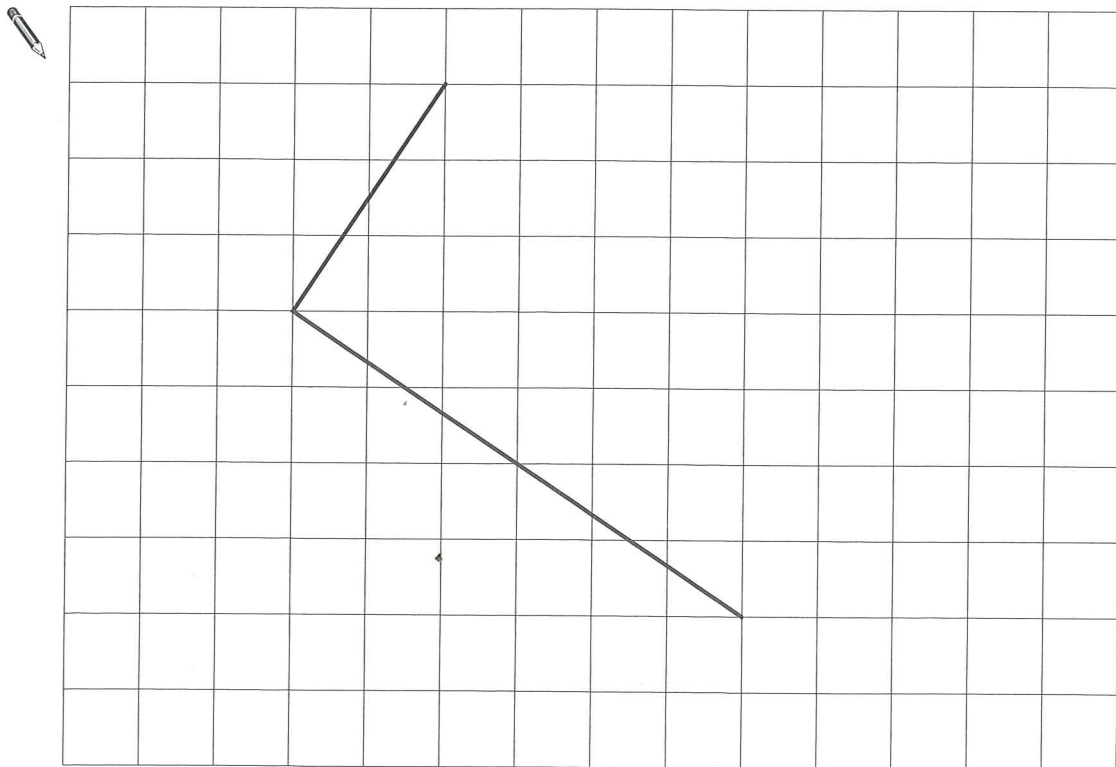

20  
1 mark

21

Put a ring around **all** the square numbers.

4

7

24

25

36

40

21

1 mark

22

Here is a shaded rectangle drawn on a grid of centimetre squares.

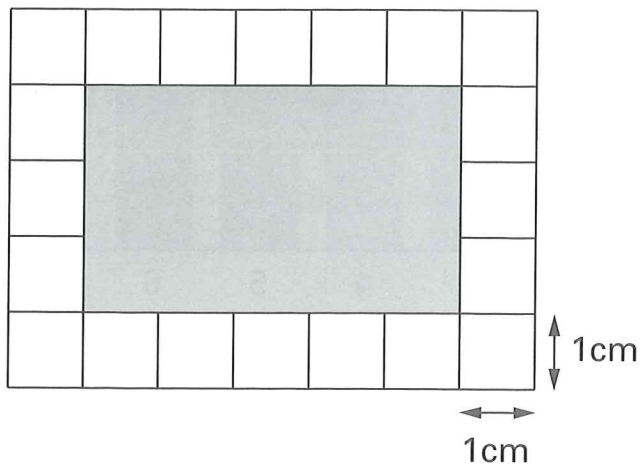
What is the **area** of the shaded rectangle?

$\text{cm}^2$
---------------

22

1 mark

23

Emma counts how many letters there are in each of 40 words.

The bar chart shows her results.

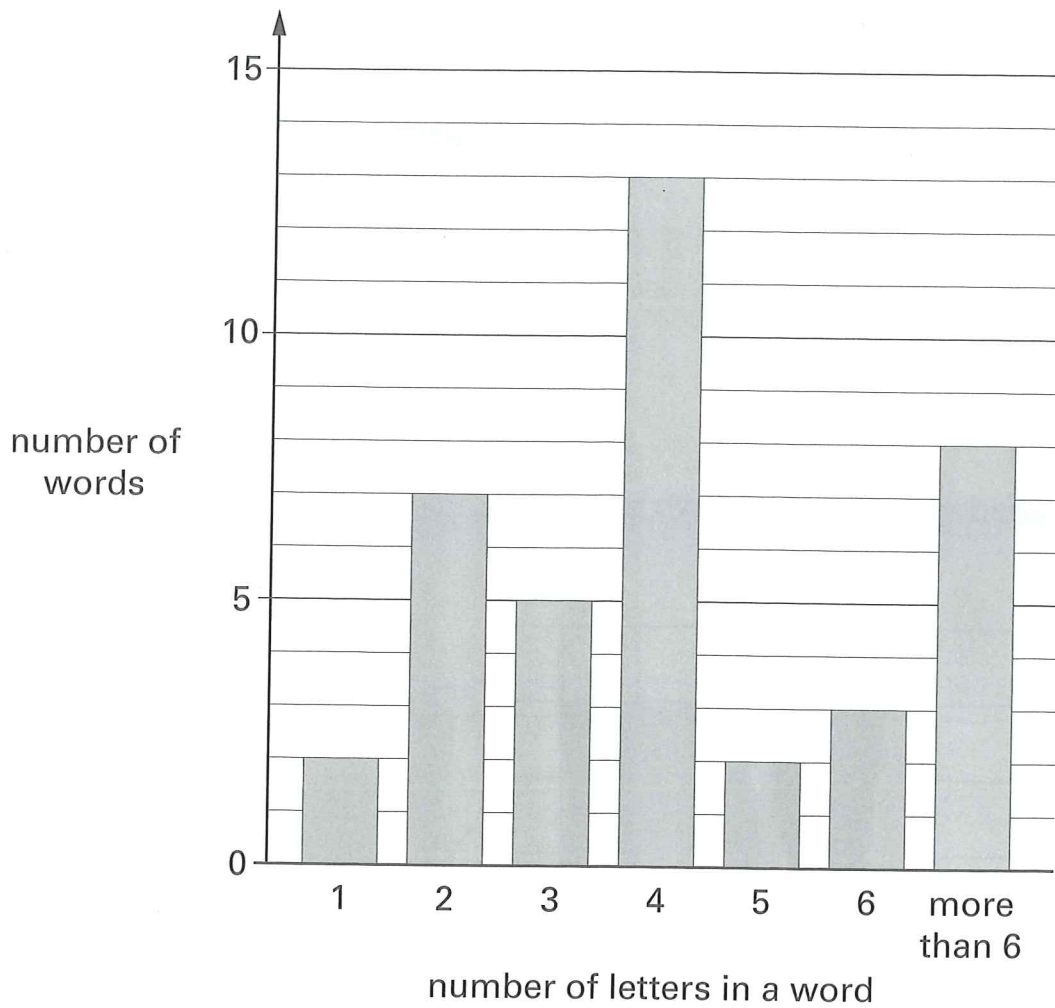

How many words have **fewer** than 4 letters in them?



23a

1 mark

What **fraction** of the 40 words have **more than** 6 letters in them?



23b

1 mark

24

Calculate 15% of 80



24

1 mark

25

Three identical blocks are placed in a line 80 centimetres long.

The gaps between the blocks are each 7cm.

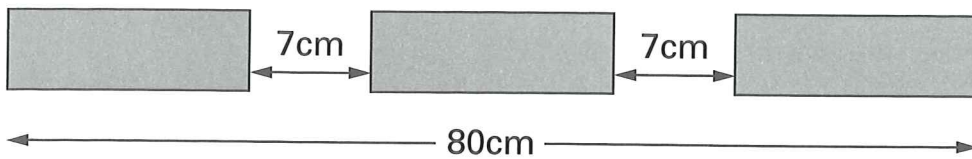

Not drawn  
to scale

Work out the length of each block.



Show  
your **method**.  
You may get  
a mark.

cm

25i

25ii

2 marks

26

Here is a triangle.

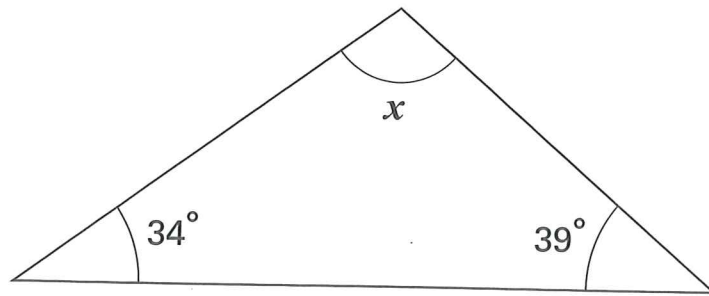



Not to scale

Calculate the size of angle  $x$ .

Do **not** use a protractor (angle measurer).

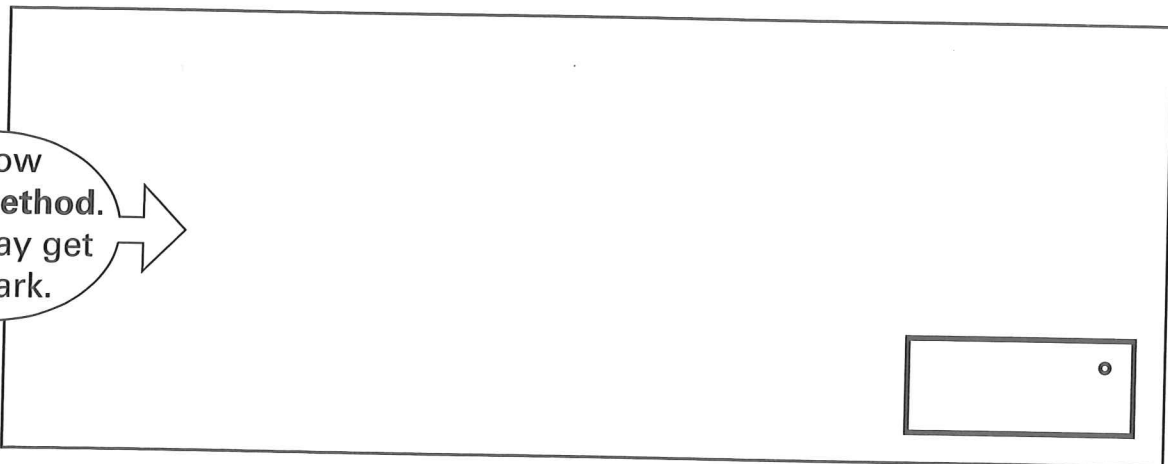
 Show your **method**. You may get a mark.





26i

26ii

2 marks

27

$n$  stands for a number between 50 and 60

Complete these statements.

One has been done for you.

$n + 10$  stands for a number between 60 and 70



$10 \times n$  stands for a number between \_\_\_\_\_ and \_\_\_\_\_

27a

1 mark

$n - 5$  stands for a number between \_\_\_\_\_ and \_\_\_\_\_

27b

1 mark

